

EXHIBITOR MANUAL



**DIVE
SHOW
.RU**

2023

CONTENTS:

Exhibition program	3
General Information	4
• Exhibition Committee	4
• Organizers office at the exhibition	4
• Exhibition Schedule	4
Forms	5
Form № 1. Participation / stand booking	6
Stand Arrangement	13
• Equipped/unequipped stands	13
• Self-adhesive visuals and vinyl banners	15
• Layout requirements for large format and interior printings	18
• Self-adhesive visuals on showcases and information desks	20
• Cost of self-adhesive visuals	23
• Design advices	23
• Self-adhesive visuals layout order (custom made)	24
Form № 2. Additional Equipment	25
Form № 2.1. Scheme of Stand	30
Form № 2.2. Additional equipment	31
• TV sets, LED screens and touch screen panels	35
• Ceiling pendants fittings	38
Form № 3. Advertising services	39
Form № 4. Badges order	47
Form № 5. Equipment delivery/removal letter	48
Map of the access	49
Work procedure at the exhibition	50
Exhibits Dismantling/Removal	52

MOSCOW DIVE SHOW 2023

V International specialized exhibition of underwater equipment

About our event:

MOSCOW DIVE SHOW it is a largest exhibition of tourism equipment, diving equipment, scuba gear and education for all “underwater” and “water” people in Russia and Eastern Europe. The basics of the exhibition are four main underwater topics: diving, underwater hunting, freediving, underwater photographing; and many various water activities as yachting, dive regattas, kiting, surfing, SUP and water tourism.

MOSCOW DIVE SHOW — it is a main exhibition of “underwater and water” people, and definitely of those who are only thinking and dreaming to “join this club”.

Main task of the Exhibition:

We collect in one place all for active leisure time under water, in the water, and next to the water.

Ideology of the exhibition:

This is an ideal platform to communicate between retail and wholesale businessmen, to develop dealer’s centers, direct sales of merchandise, to offer services to customers and to promote retail and internet shops.

Exhibitors:

- producers, distributors and sellers of merchandises for diving, underwater hunting, freediving, underwater photographing, yachting, surfing, kiting and similar water activities;
- dive resorts, liveaboard yachts, dive centers
- tourist agencies who sell dive tourism services
- dive clubs who offer education and travelling
- fishing centers who organize underwater hunting;
- travel business representatives of countries where they develop underwater tourism field;
- airlines and insurance companies offering special programs for “underwater” people travelling;
- yacht clubs and yacht schools

Our Visitors are:

- divers, freedivers, underwater hunters, underwater photographers, persons who are passionate about yachting, surfing, fishing and other underwater and water activities.

About Exhibition Organizers:

Publisher “Underwater” issues two main Russian magazines”) for underwater man: “Prededlnaya Glubina” Russia’s Dive Mag#1 (“Ultimate Depth”) and “Mir Podvodnoy Ohoty” (“The Spearfishing World”)

Welcome to exhibition MOSCOW DIVE SHOW 2023!

General information

Exhibition Organizer's Committee:

Publishing House "Underwater":

Post address: 125362, Moscow, Vodnikov Street, 2/ bldg. 17, office 12

Phone numbers: +7 (926) 456-0-456

Exhibition site: www.diveshow.ru

Exhibition management:

Project Director:

Georgy Zdanovsky

georgy@diveshow.ru

Sales Director:

Emil Latypov

sale@diveshow.ru

Accounting Department:

Olga Stankevitch

+7 (926) 553-4424

info@diveshow.ru

Site Administrator

support@diveshow.ru

Organizer's office at the exhibition:

Location Office of the exhibition's organizers: left from the main stage. We are ready to help to solve any technical problems during the assembly/dismantling works at the exhibition!

Exhibition schedule:

Assembly works: 08.02.2023 — from 10:00 to 21:00

Exhibition working hours: 09.02.2023 — from 10:00 to 19:00

10.02.2023 — from 10:00 to 21:00

11.02.2023 — from 10:00 to 21:00

12.02.2023 — from 10:00 to 18:00

Dismantling works

removal of exhibit items: 12.02.2023 — from 18:00 to 23:00

The stand that is not booked at 12:00 9th of February 2023 considered as unoccupied one. Inform the Exhibition Direction if you have no time enough to book the stand before mentioned date and time

Forms:

1. **Form №1** is to fill in to participate and to rent the Conference Hall. Please book the stand in advance on site of the Exhibition www.diveshow.ru.

Application for participation in our Exhibition (Form №1) has to be filled in by booking of free stand using the page "Hall Scheme" (www.diveshow.ru/shema.php). All unoccupied stands are shown in blue color (not shaded). Please, choose the free stand, click the chosen stand and book it. Your request for pre-booking will be sent automatically in the Sales Department. The chosen stand will be booked for you during 24 hours and our manager will contact you shortly.

If any problem of booking the stand through the site occurs, please send your request of chosen stand booking in free written mode by email to sale@diveshow.ru.

2. **Form №2** the Additional equipment order. Fill it if necessary to request additional equipment and/or services.
3. **Form № 2.1** the Stand Scheme: think over the additional equipment (to be ordered by Form №2) and standard equipment place on the stand. The stand scheme should be sent by email in our Sales Department email@diveshow.ru for the further agreement.
4. **Form №3** Advertising Services.
 - Information articles and advertising materials in exhibition's magazines issues "Predelnaya Glubina" Russia's Dive Mag#1 ("Ultimate Depth") and "Mir Podvodnoy Ohoty" ("The Spearfishing World").
 - The logo on tickets or a special issue of personalized invitation tickets.
 - Advertising during the Exhibition: the logo on entrance banners and on the main stage.
 - Rent of Conference Halls, Coffee breaks and Buffets.
5. **Form №4** the Order of badges. The entrance to the exhibition during the assembly/dismounting/exhibition working hours is allowed only with badges.
6. **Form №5** Authorization letter the Delivery/Remove. It is a letter for the taking in/out equipment, gear, exhibits. It must be filled in by the appropriate way. Representative of your company must have it in three printed and stamped copies.
7. **Form №6** Official Accredited Exhibition hotel Booking. Our Exhibition Hotel is 10% cheaper than the similar standard ones. They serve an outstanding breakfast, free shuttle services in the morning and in the evening to/from the Exhibition are offered.

Name of the organization

Booth

CONTACT DETAILS

COMPANY NAME

CONTACT NAME

ADDRESS LINE 1

ADDRESS LINE 2

CITY & POSTAL CODE

TELEPHONE #

EMAIL

BOOTH CHOICE

- I am booking unequipped booth at €172/sq.m, sq.m
- I am booking equipped booth at €207/sq.m
- I am booking an island booth I am booking a corner booth (10% extra)

BOOTH ID CAPTION

Fascia text (max. 15 symbols)

CONFERENCE ROOM

- I also want to book a conference room on Feb from : to for hours at €165/hr

- I also want to book a conference room on Feb from : to for hours at €165/hr

SIGNATURE & DATE • ДАТА, ПОДПИСЬ

Map Key:

Wall element	Стеллаж Rack, 3 shelves	Подиум Н 0,9 м Podium	Стенд 1,4 м Showcase with an arc-shaped glass	Arc-shaped element showcase	ИС Information desk with an arc-shaped element
Fascia	Clothes hanger	Display	ИС Information desk	Glass showcase, 1,4 m	ИС Information desk with doors
Power socket 220V	Folding door	Low showcase	Стол 60x60 Square table	Стол 120x60 Rectangular table	Round table
Curtain	Spot light	Chair	Б Bar stool		
Standing spotlight					

Additional accessories for the booth: furniture, lights, showcases, tech services can be ordered via Form №2 or submitting an application to sale@diveshow.ru.

Участник

Номер стенда

Бронирование оборудованного стенда

Stand 4sq. m (2x2)



	Pcs.
1. Perimeter Wall Panels 3500 x 1000 x 300	6
2. Information Desk (H=1000) Standard	1
3. Table 60 x 60	1
4. Chair (standard)	1
5. Bar stool	1
6. Spot lights	1
7. Socket (1 KW)	1
8. Waste Basket	1
9. Company Name (300x2000 mm)	1

Stand 4 кв. м (corner)



	Pcs.
1. Perimeter Wall Panels 3500 x 1000 x 300	4
2. Information Desk (H=1000) Standard	1
3. Table 60 x 60	1
4. Chair (standard)	1
5. Bar stool	1
6. Spot lights	1
7. Socket (1 KW)	1
8. Waste Basket	1
9. Company Name (300x2000 mm)	1

Участник

Номер стенда

Stand 6sq. m (3x2)



	Pcs.
1. Perimeter Wall Panels 3500 x 1000 x 300	7
2. Information Desk (H=1000) Standard	1
3. Table 60 x 60	1
4. Chair (standard)	2
5. Bar stool	1
6. Spot lights	2
7. Socket (1 KW)	1
8. Корзина для бумаг	1
9. Company Name (300x2000 mm)	1

Stand 6 кв. м (corner)



	Pcs.
1. Perimeter Wall Panels 3500 x 1000 x 300	5
2. Информационная стойка радиусная H=1000 (Таблеешница серое ЛДСП)	1
3. Table 60 x 60	1
4. Chair (standard)	2
5. Bar stool	1
6. Spot lights	2
7. Socket (1 KW)	1
8. Корзина для бумаг	1
9. Company Name (300x2000 mm)	1

Участник

Номер стенда

Stand 9sq. m (3x3)



	Pcs.
1. Perimeter Wall Panels 3500 x 1000 x 300	9
2. Information Desk (H=1000) Standard	1
3. Table 120 x 60	1
4. Chair (standard)	4
5. Bar stool	1
6. Spot lights	2
7. Socket (1 KW)	1
8. Waste Basket	1
9. Company Name (300x2000 mm)	1

Stand 9 кв. м (corner)



	Pcs.
1. Perimeter Wall Panels 3500 x 1000 x 300	6
2. Information Desk (H=1000) Standard	1
3. Table 120 x 60	1
4. Chair (standard)	4
5. Bar stool	1
6. Spot lights	2
7. Socket (1 KW)	1
8. Waste Basket	1
9. Company Name (300x2000 mm)	1

Участник

Номер стенда

Stand 10sq. m (5x2)



	Pcs.
1. Perimeter Wall Panels 3500 x 1000 x 300	9
2. Information Desk (H=1000) Standard	1
3. Table 120 x 60	1
4. Chair (standard)	4
5. Bar stool	1
6. Spot lights	2
7. Socket (1 KW)	1
8. Waste Basket	1
9. Company Name (300x2000 mm)	1

Stand 10 кв. м (corner)



	Pcs.
1. Perimeter Wall Panels 3500 x 1000 x 300	7
2. Информационная стойка H-1000 (Таблеешница серое ЛДСП)	1
3. Table 120 x 60	1
4. Chair (standard)	4
5. Bar stool	1
6. Spot lights	2
7. Socket (1 KW)	1
8. Waste Basket	1
9. Company Name (300x2000 mm)	1

Участник

Номер стенда

Stand 12sq. m (4x3)



	Pcs.
1. Perimeter Wall Panels 3500 x 1000 x 300	10
2. Information Desk (H=1000) Standard	1
3. Table 120 x 60	1
4. Chair (standard)	4
5. Bar stool	1
6. Spot lights	2
7. Socket (1 KW)	1
8. Waste Basket	1
9. Company Name (300x2000 mm)	1

Stand 12 кв. м (corner)



	Pcs. (4 x 3)	Pcs. (6 x 2)
1. Perimeter Wall Panels 3500 x 1000 x 300	7	8
2. Information Desk (H=1000) Standard	1	1
3. Table 120 x 60	1	1
4. Chair (standard)	4	4
5. Bar stool	1	1
6. Spot lights	2	2
7. Socket (1 KW)	1	1
8. Waste Basket	1	1
9. Company Name (300x2000 mm)	1	1

Участник

Номер стенда

Stand 15sq. m (5x3)

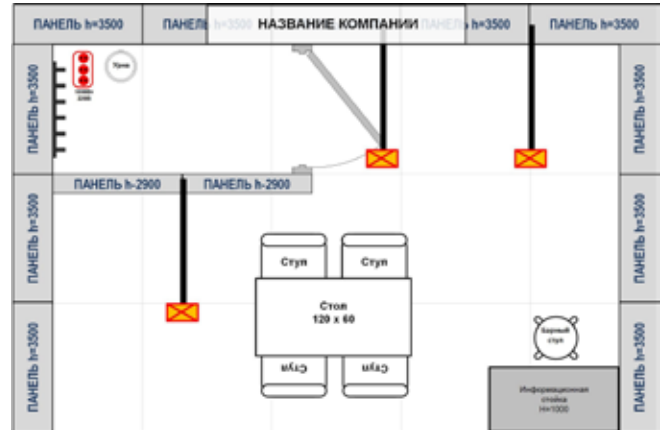

	Pcs.
1. Perimeter Wall Panels 3500 x 1000 x 300	11
2. Perimeter Wall Panels 3000 x 100 x 150	2
3. Storage room (Door + Key) (2x1) 290x100x15	1
4. Information Desk (H=1000) Standard	1
5. Table 120 x 60	1
6. Chair (standard)	4
7. Bar stool	1
8. Spot lights	3
9. Socket (1 KW)	1
10. Waste Basket	1
11. Coat Hanger	1
12. Company Name (300x2000 mm)	1

Stand 15 кв. м (corner)

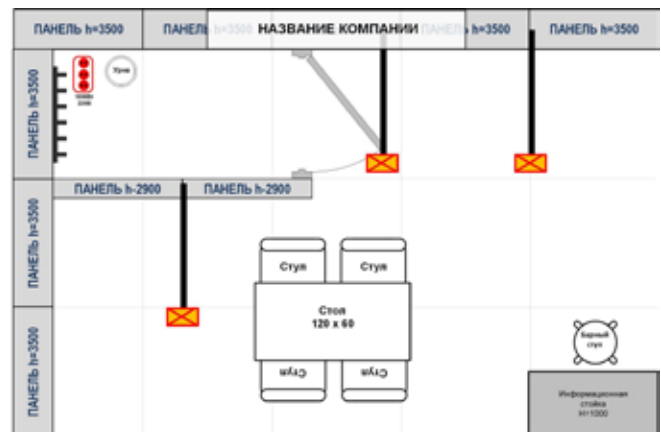

	Pcs.
1. Perimeter Wall Panels 3500 x 1000 x 300	8
2. Perimeter Wall Panels 3000 x 100 x 150	2
3. Storage room (Door + Key) (2x1) 290x100x15	1
4. Information Desk (H=1000) Standard	1
5. Table 120 x 60	1
6. Chair (standard)	4
7. Bar stool	1
8. Spot lights	3
9. Socket (1 KW)	1
10. Waste Basket	1
11. Вешалка навесная	1
12. Company Name (300x2000 mm)	1

Участник

Номер стенда

Stand 18sq. m (6x3)

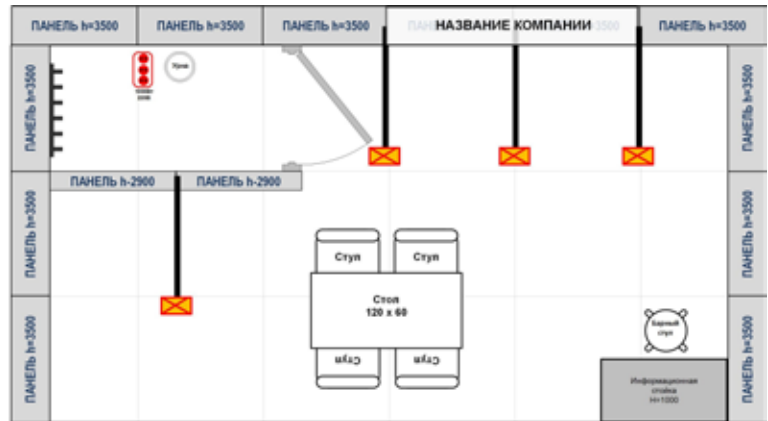

	Pcs.
1. Perimeter Wall Panels 3500 x 1000 x 300	12
2. Perimeter Wall Panels 3000 x 100 x 150	2
3. Storage room (Door + Key) (2x1) 290x100x15	1
4. Information Desk (H=1000) Standard	1
5. Table 120 x 60	1
6. Chair (standard)	4
7. Bar stool	1
8. Spot lights	4
9. Socket (1 KW)	1
10. Waste Basket	1
11. Coat Hanger	1
12. Company Name (300x2000 mm)	1

Stand 18 кв. м (corner)

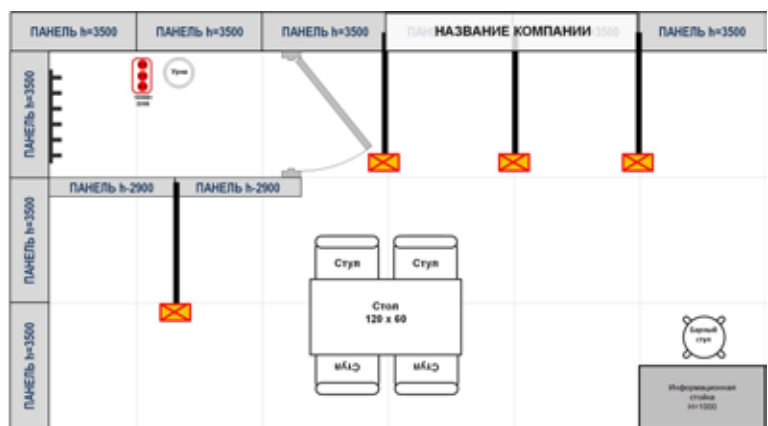
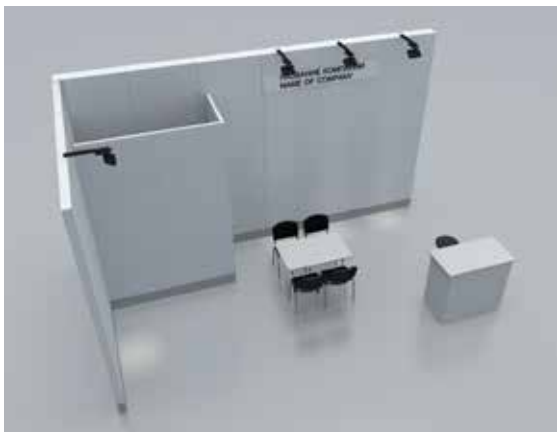

	Pcs.
1. Perimeter Wall Panels 3500 x 1000 x 300	9
2. Perimeter Wall Panels 3000 x 100 x 150	2
3. Storage room (Door + Key) (2x1) 290x100x15	1
4. Information Desk (H=1000) Standard	1
5. Table 120x60	1
6. Chair (standard)	4
7. Bar stool	1
8. Spot lights	4
9. Socket (1 KW)	1
10. Waste Basket	1
11. Вешалка напольная	1
12. Company Name (300x2000 mm)	1

Участник

Номер стенда

Stand 20sq. m (5x4)

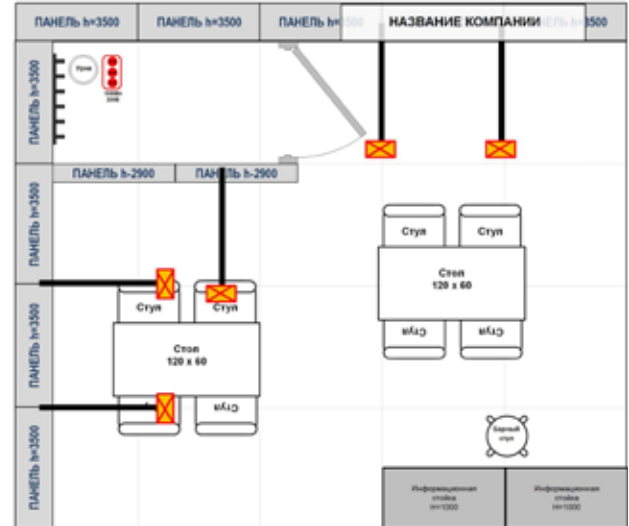

	Pcs.
1. Perimeter Wall Panels 3500 x 1000 x 300	9
2. Perimeter Wall Panels 3000 x 100 x 150	2
3. Storage room (Door + Key) (2x1) 290x100x15	1
4. Information Desk (H=1000) Standard	2
5. Table 120 x 60	2
6. Chair (standard)	8
7. Bar stool	1
8. Spot lights	5
9. Socket (1 KW)	1
10. Waste Basket	1
11. Coat Hanger	1
12. Company Name (300x2000 mm)	1

Stand 21sq. m (7x3)

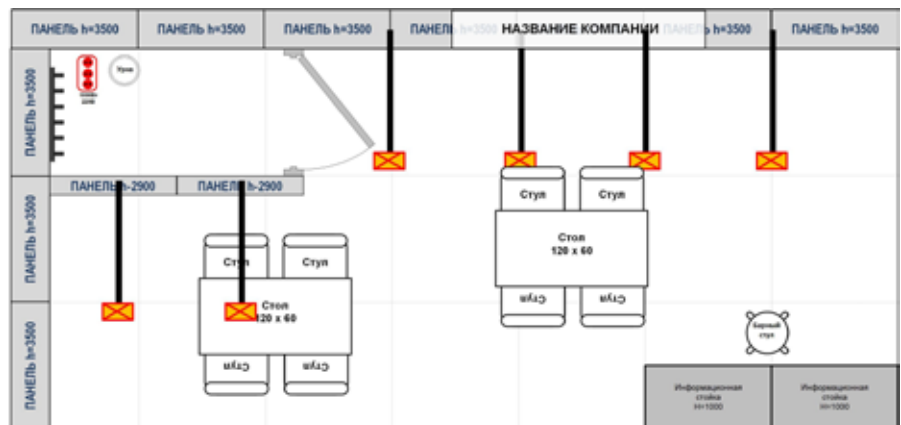

	Pcs.
1. Perimeter Wall Panels 3500 x 1000 x 300	10
2. Perimeter Wall Panels 3000 x 100 x 150	2
3. Storage room (Door + Key) (2x1) 290x100x15	1
4. Information Desk (H=1000) Standard	2
5. Table 120 x 60	2
6. Chair (standard)	8
7. Bar stool	1
8. Spot lights	6
9. Socket (1 KW)	1
10. Waste Basket	1
11. Coat Hanger	1
12. Company Name (300x2000 mm)	1

Участник

Номер стенда

Stand 24sq. m (8x3)

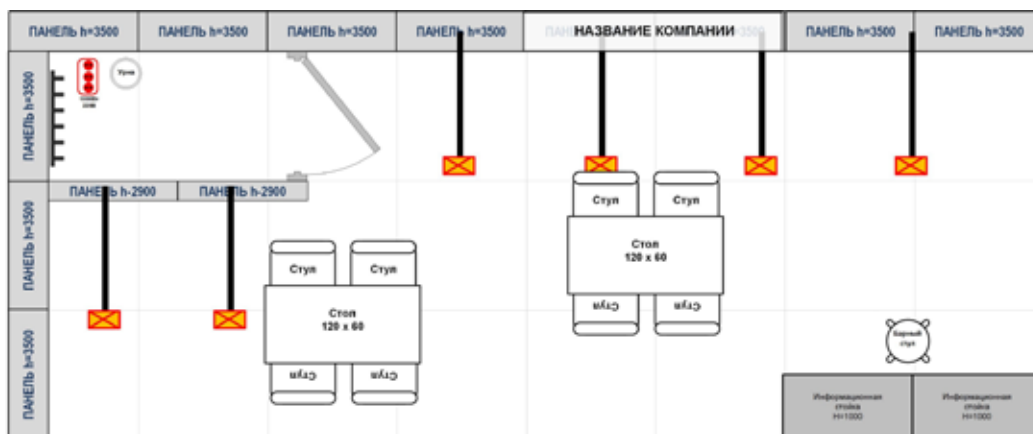

	Pcs.
1. Perimeter Wall Panels 3500 x 1000 x 300	11
2. Perimeter Wall Panels 3000 x 100 x 150	2
3. Storage room (Door + Key) (2x1) 290x100x15	1
4. Information Desk (H=1000) Standard	2
5. Table 120 x 60	2
6. Chair (standard)	8
7. Bar stool	1
8. Spot lights	6
9. Socket (1 KW)	1
10. Waste Basket	1
11. Coat Hanger	1
12. Company Name (300x2000 mm)	1

Stand 24sq. m (6x4)

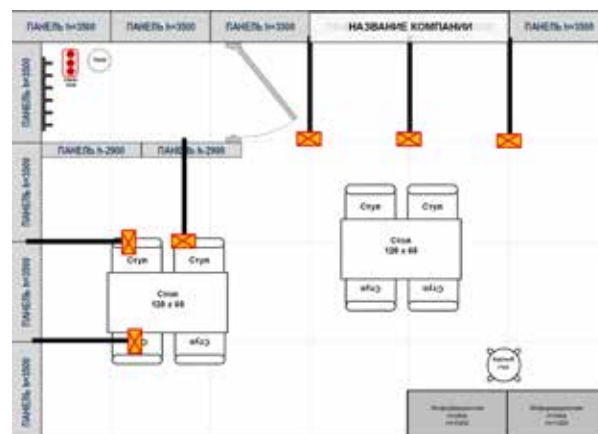

	Pcs.
1. Perimeter Wall Panels 3500 x 1000 x 300	10
2. Perimeter Wall Panels 3000 x 100 x 150	2
3. Storage room (Door + Key) (2x1) 290x100x15	1
4. Information Desk (H=1000) Standard	2
5. Table 120 x 60	2
6. Chair (standard)	8
7. Bar stool	1
8. Spot lights	6
9. Socket (1 KW)	1
10. Waste Basket	1
11. Coat Hanger	1
12. Company Name (300x2000 mm)	1

Участник

Номер стенда

Stand 25sq. m (5x5)

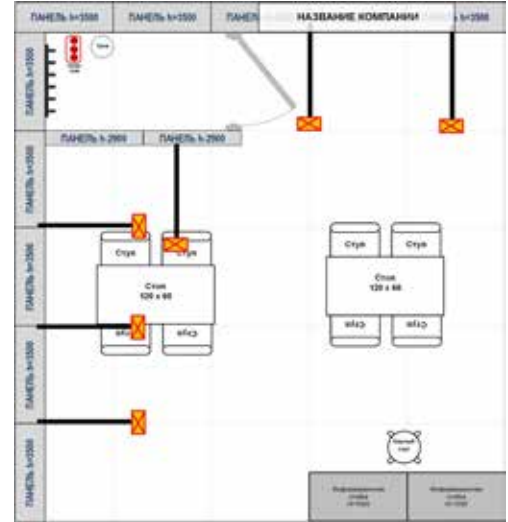

	Pcs.
1. Perimeter Wall Panels 3500 x 1000 x 300	10
2. Perimeter Wall Panels 3000 x 100 x 150	2
3. Storage room (Door + Key) (2x1) 290x100x15	1
4. Information Desk (H=1000) Standard	2
5. Table 120 x 60	2
6. Chair (standard)	8
7. Bar stool	1
8. Spot lights	6
9. Socket (1 KW)	1
10. Waste Basket	1
11. Coat Hanger	1
12. Company Name (300x2000 mm)	1

Stand 30sq. m (6x5)

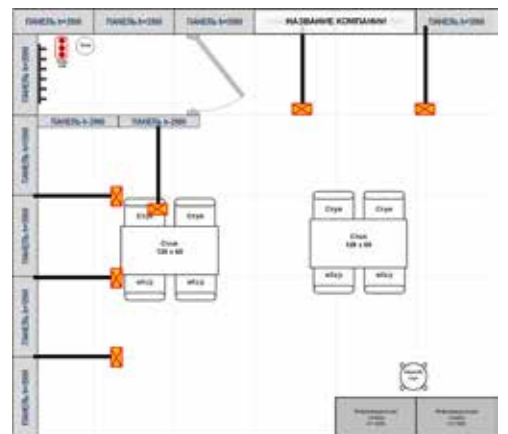

	Pcs.
1. Perimeter Wall Panels 3500 x 1000 x 300	11
2. Perimeter Wall Panels 3000 x 100 x 150	2
3. Storage room (Door + Key) (2x1) 290x100x15	1
4. Information Desk (H=1000) Standard	2
5. Table 120 x 60	2
6. Chair (standard)	8
7. Bar stool	1
8. Spot lights	6
9. Socket (1 KW)	1
10. Waste Basket	1
11. Coat Hanger	1
12. Company Name (300x2000 mm)	1

Участник

Номер стенда

Stand 32sq. m (8x4)

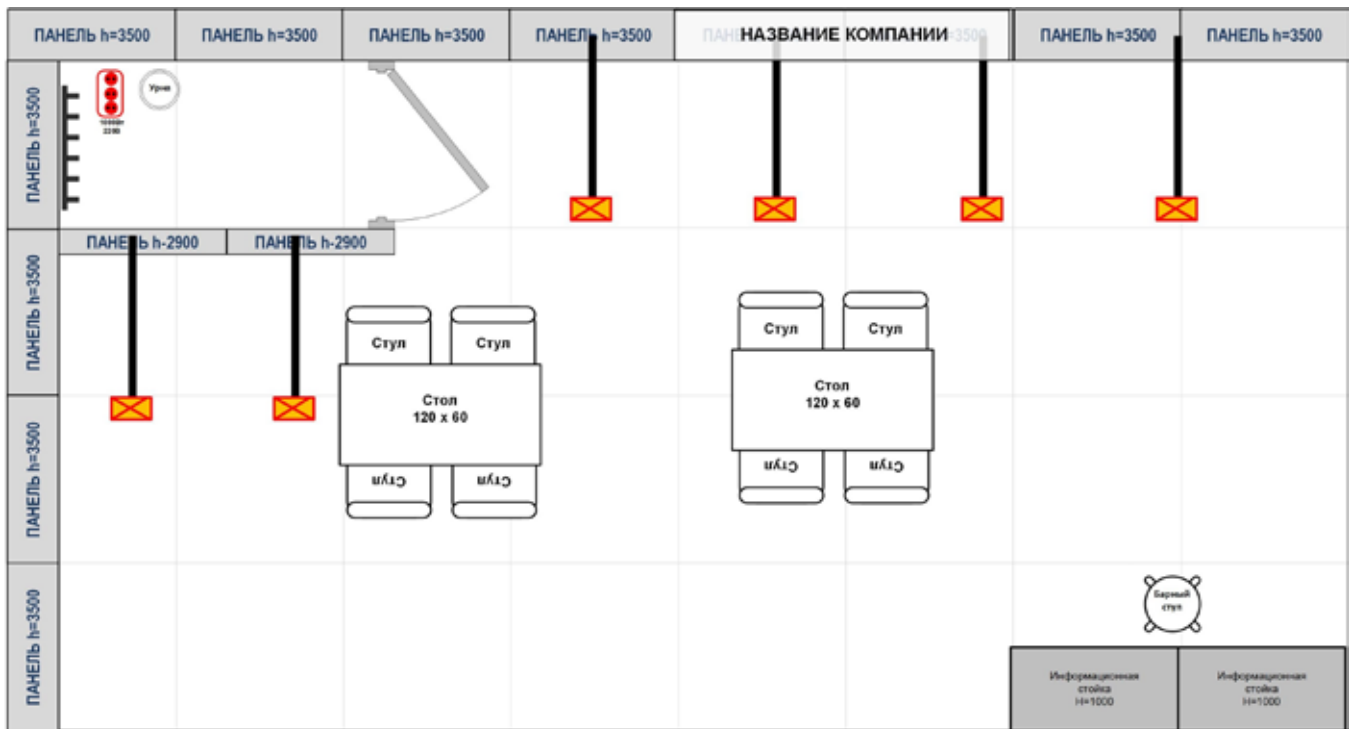

	Pcs.
1. Perimeter Wall Panels 3500 x 1000 x 300	12
2. Perimeter Wall Panels 3000 x 100 x 150	2
3. Storage room (Door + Key) (2x1) 290x100x15	1
4. Information Desk (H=1000) Standard	2
5. Table 120 x 60	2
6. Chair (standard)	8
7. Bar stool	1
8. Spot lights	6
9. Socket (1 KW)	1
10. Waste Basket	1
11. Coat Hanger	1
12. Company Name (300x2000 mm)	1

Booth Equipment

Equipped exhibition booth includes:

1. Size, type and location according to your Participant Form filled out
2. The Stand with a standard complete set, including a minimal equipment. Standard stand equipment is in conformity of the surface chosen and booked in square meters, is mentioned on exhibition site in chapter "Prices and stands" (https://moscowdiveshow.ru/exhibitors/prices_stands/);
3. An additional stand equipment is provided accordingly to the Form № 2
4. A general security of all the Exhibition pavilions and general cleaning service of Exhibition Pavilion and the aisles included
5. The Information about your company (brand) on the site of the Exhibition <https://moscowdiveshow.ru/companies/>

Unequipped exhibition booth includes:

1. Size, type and location according your Participant Form filled out
2. A general security for the Exhibition pavilion is included in the cost as far as a general cleaning service of Exhibition Pavilion and the aisles is included
3. The Information about your company (brand) placed on the site of the Exhibition <https://moscowdiveshow.ru/companies/>

Pay your attention to:

External construction company must have an accreditation (control of Exhibition Stands Technical Regulation Documents) from the company Gostiny Dvor Complex if an exclusive custom made Stand by an External Company (if not by the company Gostiny Dvor) to be build for you

On the unequipped and equipped stand area is **FORBIDDEN**:

- Carry out independent assembly and disassembly work at a prepared stand (including work with electric equipment).
 - Cover the panels independently with self-adhesive visuals.
 - Use staplers to fix any advertising materials or items on the surface of the wall panels.
 - Carry out any drilling or perforating works (or any potential damage of the constructions).
 - Smoke on the territory of the exhibition stands or Pavilion.
 - Placing additional lighting at the stands of standard buildings or mobile stands equipped with their own electric chains. Allowed only by the Authorization from Exhibition Organizers.
 - Installation of elements of non-standard stand structures and interior design which are not exhibition objects (independent additional building or decoration which might influence on stand construction by the Exhibition Participant) is allowed only by the Agreement with Exhibition Organizers after the Control of design and technical documentation of previewed works.
 - Take out the rented equipment from the stand outside the Exhibition Center.
 - Use of banners or other drapery materials is allowed only against certificates of Fire Safety Rules only.
- * *In the case of rented equipment possible damage, the cost of the damaged elements of the stand structure or additional equipment will be charged to the Exhibitor Company. An act of elements damage will be drawn up during the exhibition*

Self-adhesive visuals and vinyl banners



The easiest way to turn the lifeless white panels of exhibition structures into a stylish stand is to decorate them with self-adhesive visuals or stretch a vinyl banner. Exhibition Center Gostiny Dvor uses volumetric wooden and MDF panels of its own production for the stands installation. They are ideal for professional vinyl banner printing. High quality banners can be difficult to distinguish from more expensive self-adhesive visuals.

Professional printing and fixing of vinyl banner

Installers of Gostiny Dvor Complex stretch and fasten with an ideal tension the vinyl banner with a stapler around the entire wall panel surface. Upper and side joints are covered by with plastic strips and corners. Production and printing of 1 square meter of banner costs €47.



Use of custom made banners

A vinyl banner production by Gostiny Dvor Complex specialists is the ideal way, but it is allowed to use your own, custom made banners printed on vinyl or fabric materials. There are two mounting methods:

- Provide eyelets on the top edge and a bottom pocket for the weight. The upper part of the banner is fastened with S-shaped hooks to the groove in the upper part of the panel. The lower part of the banner is stretched by a weighting material (metal rod). Make a banner without eyelets on top, providing an upper allowance of 10 cm for fastening tightly with a stapler to the top of the panel. If you have chosen this option, in order to install wooden planks in advance in the places of the proposed fastening you must provide the exhibition management with your sketch
- The lower part can also be stretched by means of a pocket with a weighting.

During installation it is possible to purchase S-shaped hooks of the required shape and weighting rods at the Directorate.



Useful life hack — bright self-adhesive visuals, as an ideal background for selfies and photo shoots. The photo shows the stand of the Frogman brand at the Moscow

Attention! It is forbidden to attach banners to the front side of the panel with a stapler and double-sided tape. It is allowed to screw in no more than 4 self-tapping screws into the front of each panel.

Professional decoration with self-adhesive visuals

Self-adhesive visuals stand decoration is more complicated process than the banner printing. If your decision is to choose the option with decoration, we recommend a comprehensive solution with self-adhesive visuals production and installation by Gostiny Dvor Complex specialists.

Self-adhesive visuals production and stand decoration 1 sq.m is €61. per 1 sq.m

Self-adhesive visuals on the stand

It is permitted to cover the panels with self-adhesive visuals independently, but in this case, after the exhibition ends, we ask you to carefully dismantle the pasting and, if the panel is damaged, the cost of its repair must be paid. It is allowed to use only easy dismantling ORACAL 620 film.

Additionally, you can order the decoration of showcases and podiums. On the contrary, you can do not place visuals over the walls, but make only the floor equipment decoration.

Not only walls, but also furniture facades can be covered with self-adhesive visuals. And it's not expensive



The design of visuals and banners order

If you don't have custom made self-adhesive visuals design, send us photos in maximum resolution, logos and the reference terms. Our designers can create a stylish layout for you and you just have to approve it. The cost of the design is €12/1 sq.m with an area of up to 20 sq. m; €8/1 sq.m over 20 sq. m.

Requirements for layouts for large format and interior printing

The ready layout for interior printing is in TIFF.

The name of the files is required:

Booth number_booth name_unique surface number_material_width and height_if required_number of pieces.

Sample 1:

11_YarOblast_11(2)center_banner_3000x3500

Means: "Stand № 11 "Yaroslvszkaya Oblast", stand zone № 11(2), facade surface, banner, width 3000, height 3500".

Optional:

11_YarOblast_11(2) center_banner_3000x3500

Sample 2:

11_YarOblast_Friez1_taping_4000x500

Optional:

11_YarOblast_Friz_taping_4000x500

Layouts should be provided with a preview (image) in JPG or PDF format.

Color mode CMYK 8 bits (for Windows OS). The file must not contain more than one layout

Layout scale 1:1.

All text objects should be presented in the vector art

If the file has large size convert the it to *.tif format and create an archive from the file with the maximum compression level. The file size will be much smaller! The file should not contain additional alpha channels (Channels) and paths (Paths). All layers should be merged into a single layer — Background. (use the Flatten Image function or "Flatten Layers!" in Photoshop). When processing files, the embedded ICC profiles are not taken into account; the ink percentages are printed directly. The use of ICC profiles can cause color changes during printing. All significant design elements (fonts, images — heads and faces of people, etc.) should be at least 5 mm inward from the edge of the layout.

If there are light areas at the edges of the image, make a black frame one pixel thick.

Graphic resolution — from 150 to 300 dpi, depending on the size of the layout (for tasks with an area less than 0.5 square meters, a resolution of 300 dpi is recommended, for tasks over 3.0 square meters — 150 dpi).

The recommended uncompressed file size is up to 200Mb, the maximum is 1 GB.

The total amount of paint should not exceed 300%. Layouts are accepted only in CMYK 8 bits color mode! Pay attention to some aspects: To obtain high-quality black color according to CMYK, the parameters should be as follows: C50%, M50%, Y50%, K100%. Note that the color saturation decreases by 10% when print on a banner mesh, During the files processing embedded ICC profiles are not taken into account; the values of ink percentages are printed. Using ICC profiles can lead to color changes during printing.

The resolution of photos in the layout should be as high as possible (as far as the quality is lost when magnified more than twice).

File resolution should be optimal. Insufficient file resolution will lead to the appearance of noticeable pixels during billboards production and "jagged" line boundaries. Increasing the resolution will significantly increase the work on the file and its processing, but the print quality will not change.

The quality and resolution of the original images that you place in the layout production for the outdoor advertising are very important. It should be borne in mind that the image that you look at in A4 format does not always looks like the same when it is in 3x6m size or more.

All layouts must be sent by email@diveshow.ru; Please mention the name of the layout and the number of the stand in the subject line.

Walls panels dimensions and the final layout of the visuals

Despite the fact that there are several types of standard wall panels used for construction, the exact dimensions of each wall stand may vary due to the different configuration and number of stands on a particular “island”. After the stand booking, you must request the exact dimensions for the preparation of a design H = — layout or manufacturing of custom made banners.

Brand “Exclusive” wall panels:

Back panel — 3500x1000x300 mm.

Wall panels for the back room panels are 2900x1000x150 mm. The panels are mounted rigidly, the joints are puttied, and the walls panels are painted in a corporate light gray color.

Frieze logo

Fix the company logo as a transparent film on the back panel of the stand.

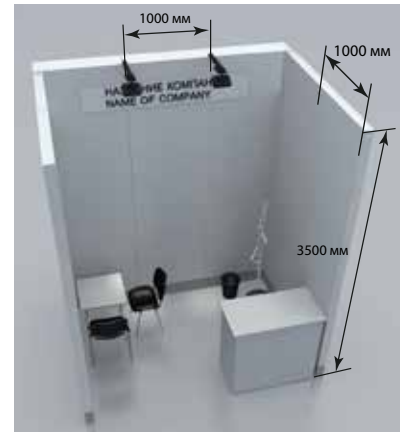

With Custom made wall designs no company logo is needed. Additionally, it possible to order a colored logo as self-adhesive visual.

Frieze Logo (1 color) — €80

Frieze Logo (Many colors) — €112

Self-adhesive visuals on information desks

The size of the structural wall panels "Exclusive":

The back wall is 3500x1000x300 mm.
Wall panels for the back room are 2900x1000x150 mm.

The panels are mounted rigidly, the joints are puttied, and wall panels are painted in a corporate light gray color. The exact dimensions (taking into account all the intricacies of the constructions) are requested by mail at email@diveshow.ru, not forgetting to indicate in the subject line the name of the model and the number of the stand.

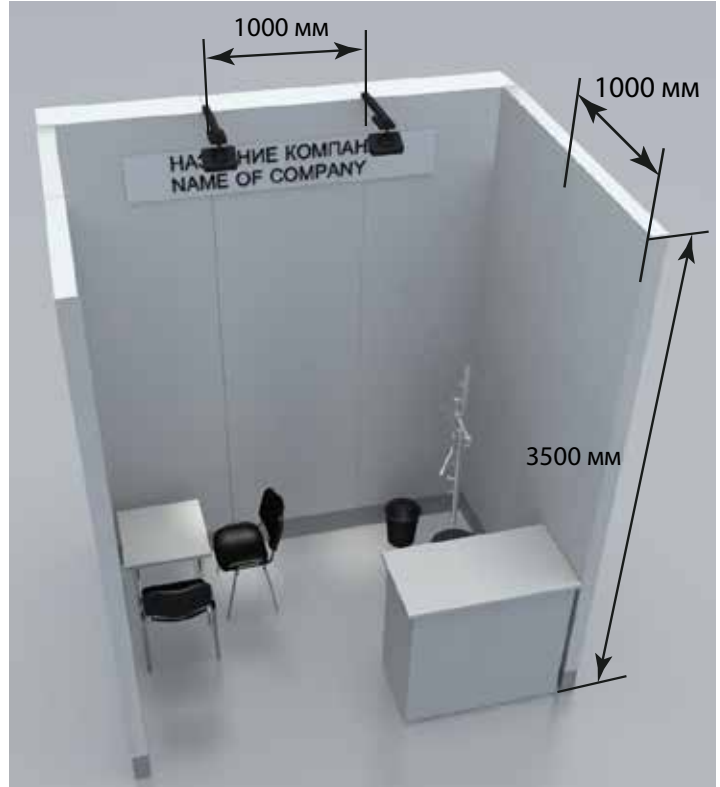

Places of self-adhesive visuals on Information desk and podium

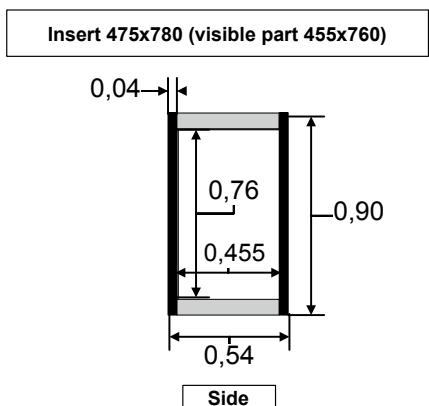
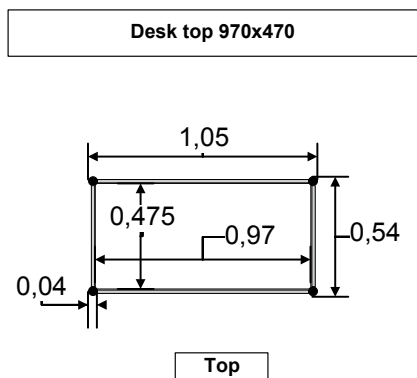
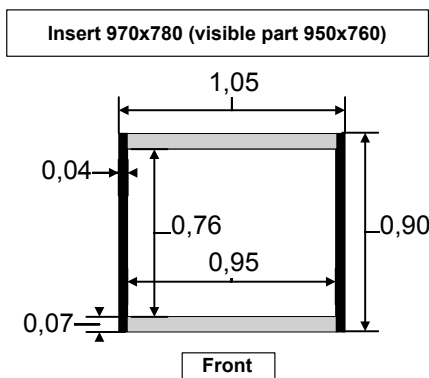

**Information desk
0,9x1,0x0,5 m**

Desk top 970x475
Insert 970x780
(visible part 950x760)
Side insert 475x780
(visible part 455x760)

The maximum admissible weight on the desk top is up to 10 kg

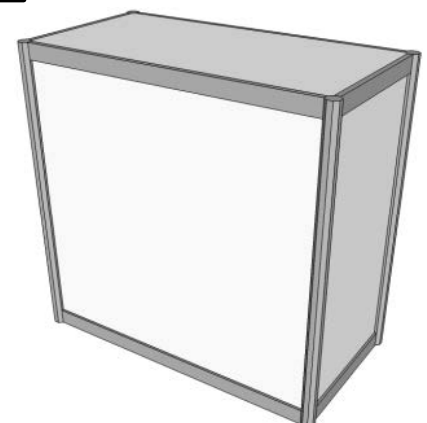

Self-adhesive visuals on the radial information desk

<p>Insert 1530x780 (visual part 1510x760)</p> <p>Front</p>	<p>Desk top R=1 m</p> <p>Desk top, shelf</p>
<p>Insert 475x780 (visual part 455x760)</p> <p>Side</p>	<div style="border: 1px solid black; padding: 5px;"> <p align="center">Radial Information desk H=0,9, R=1 m</p> <p align="center">Desk top R=1 m Frontal insert 1530x780 (Visible part 1510x760) Sides insert 475x780 (visible part 455x760)</p> <hr/> <p align="center">The maximum admissible weight on the desk top is under 10 kg</p> </div>

Self-adhesive visuals on the low showcase 900x1000x500 mm

<p>Front</p>	<p>Top</p>
<p>Side (and front of showcase 0,9x0,5x0,5)</p>	<div style="border: 1px solid black; padding: 5px;"> <p align="center">Showcase 0,9x1,0x0,5 m</p> <p align="center">Frontal insert 970x490 (visible part 950x470) side insert 475x490 (visible part 455x470) Front glass 970x240 (visible part 950x220) Side glass 470x240 (visible part 450x220) Glass top panel 970x470</p> <hr/> <p align="center">Max.admissible weight for the showcase glass shelf is under 5 kg. Max. weight for glass top (without reinforcement) is less than 10 kg. Max/ weight is for reinforced glass top is under 50 kg</p> </div>

Self-adhesive visuals on the low showcase

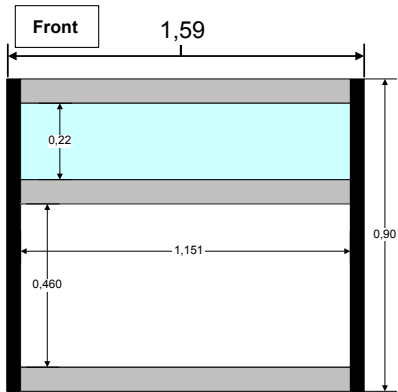

Radial Desk Top R=1 m

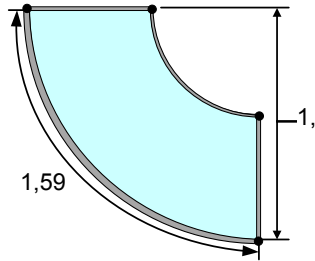

Side
(and front pane
of showcase
0,9x0,5x0,5)

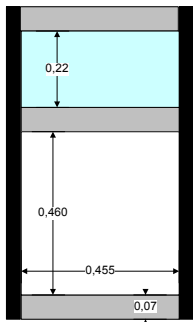

Radial Showcase H=0,9, R=1 m

Front insert 1530x490 (visible part 1510x470)
Side Insert 475x490 (visible part 455x470)

Max. admissible weight for the showcase glass shelf
is under 5 kg. Max. Weight for glass top
(without reinforcement) is less than 10 kg.
Max. weight is for reinforced glass top is under 50 kg

Self-adhesive visuals on the showcase 100x500x2500mm. Glass 1000 mm

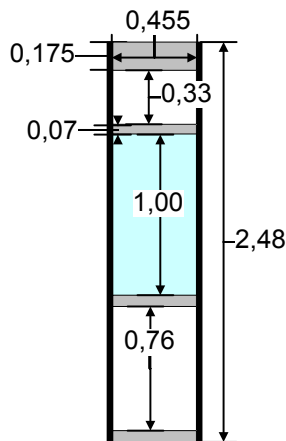
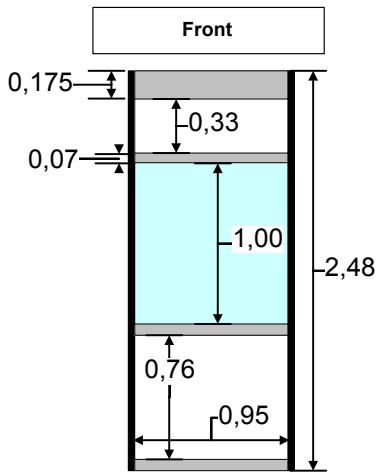

Side
(and front of showcase
2,5x0,5x0,5m)

Showcase 2,5x1,0x0,5 m glass height: 1,0 m

Low part Frontal insert 970x780 (visible part 950x760)
Upper part Front insert 970x350 (visible part 950x330)
Front glass 1020x970 (visible part 1000x950)
Low part side insert 475x780 (visible part 455x760)
Side Insert Top part 475x350 (visible part 455x330)
Side glass 1020x475 (visible part 1000x455)

Showcase 2,5x0,5x0,5 m glass height: 1,0 m

Low part insert 475x780 (visible part 455x760)
Upper part insert 475x350 (visible part 455x330)
Glass 1020x475 (visible part 1000x455)

Maximal admissible
weight for the showcase
glass shelf is under 5 kg,
for the glass top
is under 10 kg



Self-adhesive visuals decoration works

Work specification	Surface, sq.m	Production / decoration (self-adhesive visuals, €)	Production decoration (banners), €
Side panel 3500x1000mm decoration	3,5	213,5	164,5
Side panel 3000x1000mm decoration	3,0	183	141
Information desk or podium decoration (front panel)	0,76	46,36	
Radial information desk decoration (front panel)	1,2	73,2	
Decoration of any information desk or of podium (side panel)	0,37	22,57	
Showcase front panel 1000x500x900mm decoration	0,48	29,28	
Showcase front panel 500x500x900mm decoration	0,24	14,64	
Decoration of any low showcase's side panels	0,48	29,28	
Radial showcase front panels 1000x1000x2500mm decoration	1,13	68,93	
Radial showcase side panels Decoration	0,7	42,7	
Showcase front panels 1000x500x2500mm decoration	0,8	48,8	
Showcase side panels 1000x500x2500mm decoration	0,7	42,7	
Showcase front panels 500x500x2500mm decoration	0,5	30,5	
Showcase side panels 500x500x2500mm decoration	0,5	30,5	

Design tips. Design tips

- Carefully consider the location of furniture and pendant fittings when create the sketch of your self-adhesive visuals. Chose those parts of the walls that will definitely be visible to visitors. Place your logo or a main picture there. The location of the photo or logo on the wall should be ideal for photographing a person standing in front of it. Optimal height is from 1.5 to 2 meters.
- Even if you have dozens of beautiful models or tourist objects pictures in your photo bank, try to choose one photo that precisely presents the main meaning of your stand.
- Few words, but much meaning. No reason to write evident things as “best, bargain, safe”. Better to write briefly: “Five sharks species for 999\$”, “Unusual Caribe Islands. Divers on boars” and so on...
- If you do not have a beautiful photo in very high resolution (from 50 MB, TIFF format), place your logo and slogan on a colored background. Blurred photography on the walls of the stand is definitely a bad option. Don't forget about a complex solution especially if you have branded colors. Think about self-adhesive visuals not only on the walls, but also on the floor equipment. If there are no brand colors, choose classics: neutral blue tones (after all, this is an exhibition of a “water man”), and if you want to stand out: a yellow or red background will definitely help you. Contrast black color on the walls looks very stylish. A bit more about the colors: as a final touch of the ideal design is the choice of colored carpet. The range includes all basic colors. The most popular colors are red and blue but the beautiful stone floor of the Gostiny Dvor is perfect even without a carpet.

Order a custom made layout to the exhibition designers

1. Carefully think over the location of furniture and hanging structures.
2. Choose those parts of the walls that will definitely be visible to visitors. Place your logo or central picture there. Sketch the location of the logo, photo, and text on the panels.
3. Even if you have dozens of beautiful models or tourist objects pictures in your photo bank, try to choose one photo that precisely presents the main meaning of your stand.
4. If you do not have a beautiful photo in very high resolution (from 50 MB, TIFF format), place only your logo and slogan on a colored background.
5. Create a text document in Word with detailed comments on the sketch, color background, slogan, etc.
6. Upload a folder with a sketch, photo, logo (vector image) and a text file with comments to convenient file sharing service — Google Disc. Send the download link to sale@diveshow.ru with the subject line "TK for stand XXXXX". In a week a custom made design layout will be offered to you for approval. Do not forget, that the file should be opened for any person, who has the link.

Deadlines

It is better to spend February on preliminary work with visitors and business partners. Refresh catalogs and prices, come up with promotions and special offers, post the latest news on social networks, and please send them to our PR Department at pr@diveshow.ru. All technical questions about the stand as an additional equipment, an approval the self-adhesive visuals layout must be completed in February and even better in January then our specialists will give you maximum attention.

Name of the organization

Booth

Name	Specification	Measurement	Price, €	Amount	Total
Wall, door, carpet					
1	Carpet covering (color optional)	sq.m.	38		
2	Wall element	3500x1000x300	mm	116	
3	Wall element	2900x1000x150	mm	99	
4	Wall element with door	2900x1000x150	pcs.	136	
Showcase, cabinet, desk					
5	File cabinet H=1000	1000x500	pcs.	112	
6	File cabinet H=1000	500x500	pcs.	102	
7	File cabinet H=700	1000x500	pcs.	97	
8	File cabinet H=700	500x500	pcs.	82	
9	Showcase H=1000 mm	1000x500	pcs.	102	
10	Showcase H=1000 mm	500x500	pcs.	104	
11	Showcase H=1000 mm	500xR500	pcs.	131	
12	Showcase, H=1000 (diagonal shelf)	R1000xD500	pcs.	142	
13	Showcase, H=2500 + 1 lamp	R500x500	pcs.	217	
14	Showcase, H=2500 + 1 lamp	500x500	pcs.	204	
15	Showcase, H=2500 + 2 lamp	1000x500	pcs.	268	
16	Showcase, H=2500 + 2 lamps (diagonal shelf)	R1000xD500	pcs.	246	
17	Additional shelf (File Cabinet / Information Desk)	-	pcs.	6	
18	Additional shelf (glass)	-	pcs.	17	
19	Information desk. H=1000	500xR500	pcs.	99	
20	Information desk. H=1000	1000x500	pcs.	100	
21	Information desk. H=1000	R1000xR500	pcs.	110	
22	Information desk. H=1000	500x500	pcs.	65	
23	Podium, H=70,H=470,H=700,H=1000	R1000x1000	pcs.	78	
24	Podium, H=70,H=470,H=700,H=1000	R1000xR500	pcs.	53	
25	Podium, H=70,H=470,H=700,H=1000	R500x500	pcs.	51	
26	Podium, H=70,H=470,H=700,H=1000	1000x500	pcs.	50	
27	Podium, H=70,H=470,H=700,H=1000	1000x1000	pcs.	59	
28	Podium, H=70,H=470,H=700,H=1000	500x500	pcs.	48	
29	Showcase "Premium"	H=1000	pcs.	93	
30	Showcase "Premium"	H=3500	pcs.	212	
31	Fencing (flexible)	-	m	7	
32	Fence post tape (red, black, blue)	-	pcs.	38	
Sofa, armchair, chair and table					
33	2-seat sofa "Baron" (white / black pleather)	-	pcs.	125	
34	3-seat sofa "Baron" (white / black pleather)	-	pcs.	170	

Name of the organization

Booth

Name	Specification	Measurement	Price, €	Amount	Total
35	Armchair (Black / White)	-	pcs.	80	
36	Glass Table Standart	H=75cm, D=70cm	pcs.	104	
37	Table H=750	600x600	pcs.	61	
38	Table H=750	1200x600	pcs.	72	
39	Barstool ZETA (Black)	Standart	pcs.	31	
40	Chair standart (Black)	-	pcs.	16	
41	Glass Table "Hydra"	H=75cm, D=90cm	pcs.	129	
42	Barstool — D70 (White / Grey)	H=110cm, D=70cm	pcs.	133	
43	Bar glasstable — D80	H=105cm, D=80cm	pcs.	136	
44	Barstool "Latina" (Black / White)	-	pcs.	53	
45	Barstool "Marko" (Black / White)	-	pcs.	29	
46	Chair standart (Grey)	-	pcs.	19	
Trading equipment					
47	Chrome-plated trading grid, thickened frame	2000x800 (cell 50)	pcs.	51	
48	Trading grid (Grey)	1800x800 (cell 50)	sq.m.	29	
49	Metal shelving	-	pcs.	78	
50	Coat hanger on the wall	-	pcs.	14	
51	Coat hanger on the floor	-	pcs.	40	
52	Brochure holder "Parus"	On the floor	pcs.	40	
53	Full-length mannequin, standard	-	pcs.	199	
54	Full-length mannequin, gloss	-	pcs.	302	
55	Hooks for a trade grid	-	5 pcs.	6	
56	Economy panel	-	pcs.	80	
Other equipment					
57	Advertising cube (Stationary)	-	pcs.	78	
58	Advertising cube (Spinning)	With light	pcs.	225	
59	Advertising cube (Stationary)	With light	pcs.	97	
60	Cooler + 1 Water bottle /19 litres	-	pcs.	142	
61	Water bottle /19 litres	-	pcs.	31	
62	Lock for the door or something else	-	pcs.	4	
63	Tribune Titan 1	-	pcs.	165	
64	Refrigerator 150l.	-	pcs.	144	
65	Refrigerator 80l.	-	pcs.	112	
66	Coffee machine (+1 kg Coffee)	-	pcs.	236	
67	ECO Wastepaper basket (3-sections)	-	pcs.	12	

Name of the organization

Booth

Name	Specification	Measurement	Price, €	Amount	Total
Banners and pasting the film					
68	Cast banner	720dpi	sq.m.	30	
69	Self-adhesive film	720dpi	sq.m.	34	
70	Banner stuffing service	-	sq.m.	26	
71	Self-adhesive film wrapping service	-	sq.m.	39	
72	Making a letter - H=100 mm. "ORACAL"	Series 641	pcs.	6	
73	Making a letter - H=150 mm. "ORACAL"	Series 641	pcs.	8	
74	Making a letter - H=75 mm. "ORACAL"	Series 641	pcs.	4	
75	Making a logo for a cube (many colors)	Series 641	pcs.	170	
76	Making a logo for a cube (1 color)	Series 641	pcs.	114	
77	Making a logo for a frieze (many colors)	Series 641	pcs.	133	
78	Making a logo for a frieze (1 color)	Series 641	pcs.	95	
79	Making a new logo for your company	-	pcs.	On request	
80	Banner stuffing service (Your banner)	-	sq.m.	39	
81	Self-adhesive film wrapping service (Your self-adhesive film)	Series 641	sq.m.	39	
82	Layout of banners and self-adhesive films		sq.m.	On request	
Electrical services and equipment					
83	Spotlight halogen	-	pcs.	78	
84	Spotlight halogen on a rod	-	pcs.	80	
85	Spotlight halogen on a rod, H> 2500	-	pcs.	123	
86	Spotlight halogen, H> 2500	-	pcs.	123	
87	Metal-halide spotlight	-	pcs.	127	
88	Metal-halide spotlight, H > 2500	-	pcs.	131	
89	Plug socket up to 1000 W (Standard)	(220W)	pcs.	33	
90	Plug socket up to 1000 W (Standard) 24 hours	(220W)	pcs.	40	
91	Plug socket up to 1500 W	(220W)	pcs.	36	
92	Plug socket up to 1500 W 24 hours	(220W)	pcs.	40	
93	Plug socket up to 2500 W	(220W)	pcs.	44	
94	Plug socket up to 2500 W 24 hours	(220W)	pcs.	50	
95	Socket, plug 16A, 32A	-	pcs.	21	
96	Luminescent lamp	-	pcs.	40	
97	Mini-halogen lamp	-	pcs.	33	
98	SPOT lamp on the busbar	-	pcs.	33	
99	SPOT lamp on the busbar H > 2500	-	pcs.	50	
100	LED spotlight on a pole 1 m	30w	pcs.	65	

Name of the organization

Booth

Name	Specification	Measurement	Price, €	Amount	Total
101 LED spotlight on a pole 1.5 m	30w	pcs.	93		
102 Spot halogen	-	pcs.	36		
103 Spot halogen H > 2500		pcs.	46		
104 Electric service panel	-	pcs.	117		
TV, LED screen					
105 Plasma panel 42-46 " (On the wall / On the floor)	-	pcs.	378		
106 Plasma panel 50" (On the wall / On the floor)	-	pcs.	444		
107 LED Screen	3000x1500mm	pcs.	3150		
108 Additional module for LED Screen (from 3000x1500mm)	500x500mm	pcs.	175		
Plumbing services					
109 Bringing water on your booth	-	pcs.	216		
110 Taking water from your booth	-	m	38		
111 Water connection with washer / hot + cold water / (Contractor's equipment)	-	pcs.	302		
Fastening banners and constructions to the ceiling					
112 Suspension point up to 10 kg	-	pcs.	284		
113 Suspension point up to 50 kg	-	pcs.	378		
Floristics					
114 Aglaonema Friedman (30/11) / Silver (40/120)	-	pcs.	331		
115 Anturium (75/30) / Aglaonema (70/30)	-	pcs.	217		
116 Dracena 40/150	-	pcs.	340		
117 Pahira 40/190	-	pcs.	368		
118 Pahira Aquatica 27/140	-	pcs.	312		
119 Aglaonema Silver 17/55	-	pcs.	104		
120 Dracena Compacta (27/100) / Hawaiian (27/120)	-	pcs.	312		
Rent of the conference-hall and a meeting room					
121 Conference-hall		hour	227		
122 Meeting room for 10 people	3 hours	hour	312		
123 Meeting room for 10 people	5 hours	hour	416		
124 Meeting room for 10 people	12 hours	day	623		
Staff					
125 Staff members for work at a booth	day	per-son	133		
126 Interpreter / Booth assistant	day	per-son	265		
Additional invitations with your logo					
127 Series of personal invitations	20 pcs	pcs.	95		

Name of the organization

Booth

Name	Specification	Measurement	Price, €	Amount	Total
Cleaning service					
128	One-time dry cleaning	Разовая (1 кв.м.)	sq.m.	3	
129	One-time wet cleaning	Разовая (1 кв.м.)	sq.m.	4	
130	Cleaning service for an immediate cleanup	1 раз		29	
Unloading/loading					
131	Rent of a trolley on wheels	30 minutes	pcs.	29	
132	Rent of a hydraulic trolley	30 minutes	pcs.	57	
133	Rent of a loader with a trolley (without responsibility for the safety of the cargo)	30 minutes	pcs.	67	
134	Rent of a loader with a trolley (with responsibility for the safety of the cargo)	30 minutes	pcs.	95	
135	Unloading (loading) of goods delivered by road	100 kg.	kg.	38	
136	Forklift, up to 2.5 tons	1 time	pcs.	114	
Advertisement					
137	Advertising block in the exhibition issue of the magazine Ultimate Depth or World of Spearfishing (as a gift to all visitors)	1/16 part	Part	63	
138	Advertising block in the exhibition issue of the magazine Ultimate Depth or World of Spearfishing (as a gift to all visitors)	1/8 part	Part	104	
139	Advertising block in the exhibition issue of the magazine Ultimate Depth or World of Spearfishing (as a gift to all visitors)	1/3 part	Part	623	
140	Advertising block in the exhibition issue of the magazine Ultimate Depth or World of Spearfishing (as a gift to all visitors)	1/1 part	Part	1550	
141	Информационная статья 2 стр. + рекламный модуль 1/1			2500	
142	Leaflet "Hall plan and poster", edition 20000 copies. Standard banner			167	
143	Leaflet "Hall plan and poster", edition 20000 copies. Big banner			312	
144	Radio advertisement during the exhibition		pcs.	57	

All equipment is leased for temporary use. The above prices include transportation, assembly and disassembly of equipment.

Name of the organization

Booth

Fascia board text

For open corner booths, specify text for either side

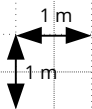
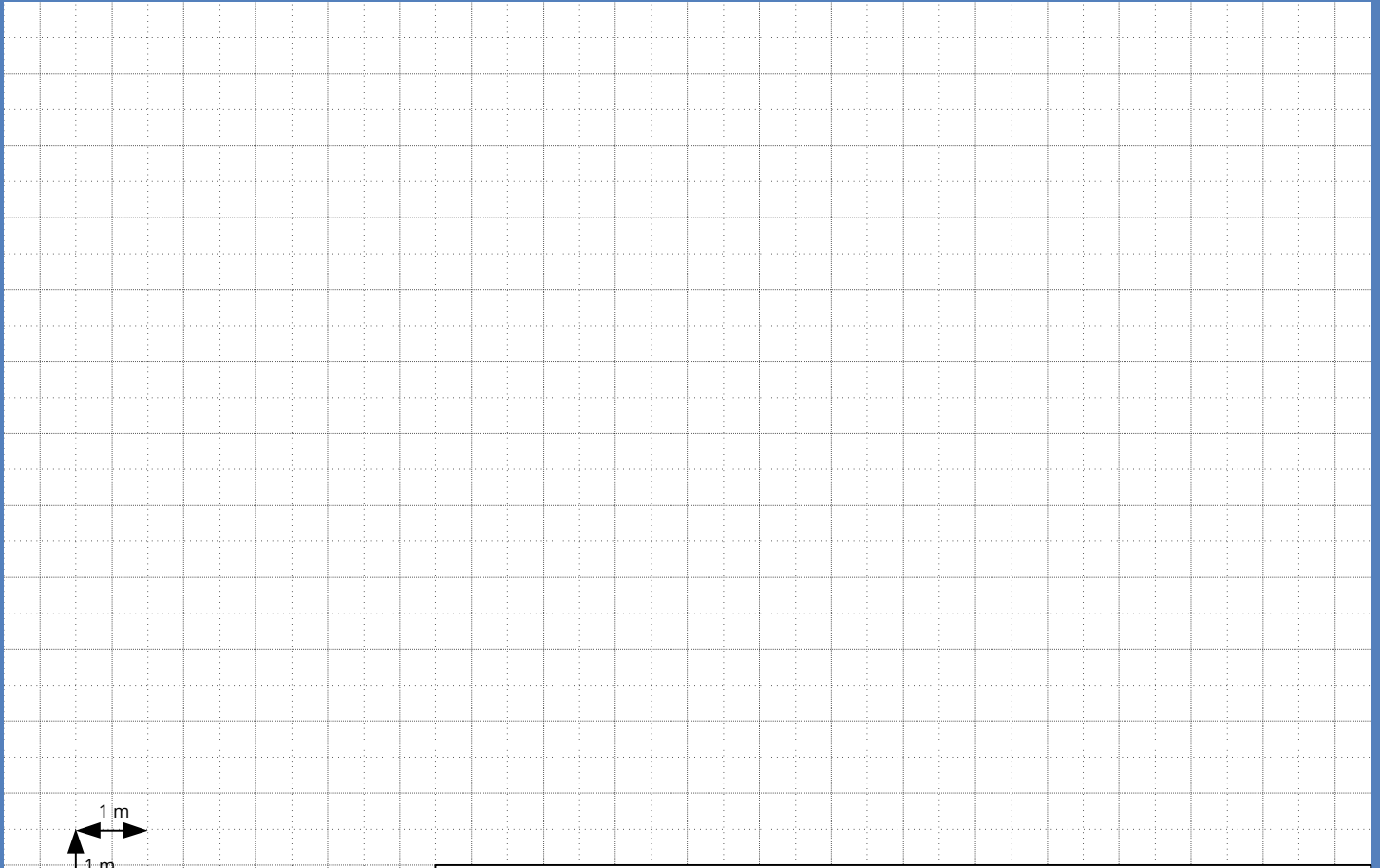

* If you have not found key symbols for some equipment, please add your comments

Comments

Example scheme of the booth

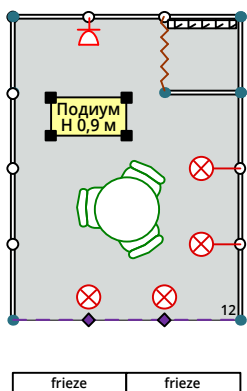

Map Key:

Wall element	Стеллаж Rack, 3 shelves	Подиум Н 0,9 м Podium	Стекло 1,4м Showcase with an arc-shaped glass	Arc-shaped element showcase	Information desk with an arc-shaped element
Fascia	Display	Low showcase	Информационный стол Information desk	Стекло 1,4 м Glass showcase, 1.4 m	Информационный стол с дверями Information desk with doors
Стойка для одежды Clothes hanger	Кресло Chair	Стол Барный Bar stool	Стол 60x60 Square table	Стол 120x60 Rectangular table	Стол Round table
Розетка 220В Power socket 220V					
Складная дверь Folding door					
Штора Curtain					
Спот-лайт Spot light					
Светильник напольный Standing spotlight					

Additional equipment samples

Exhibition furniture



20
Information desk
H=1000 (MDF light grey
color) 1000x500



6
Cabinet
H=1000
500x500



7
Cabinet
H=700
1000x500



8
Cabinet
H=700
500x500

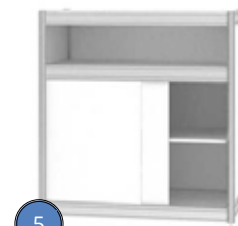

5
Cabinet
H=1000
1000x500



10
Showcase
H=1000
500x500



11
Showcase
H=1000
500xR500



12
Radius showcase
H=1000
R1000xR500



9
Showcase
H=1000 mm
1000x500



13
Showcase,
H=2500
+ 1 light fitting R500x500



14
Showcase,
H=2500
+ 1 light fitting 500x500



15
Showcase,
H=2500
+ 2 light fittings
1000x500



16
Showcase,
H=2500
+ 2 light fittings 500x500



30
Showcase «Premium»
H=3500

Конструктив SYMA



19
Information desk
H=1000
500xR500

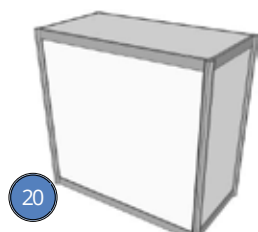

20
Information desk
H=1000 (MDF light grey
color) 1000x500

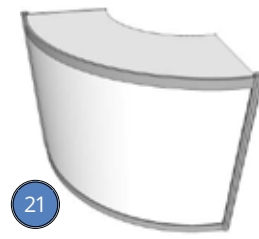

21
Information desk
H=1000 (MDF light grey
color) R1000xR500

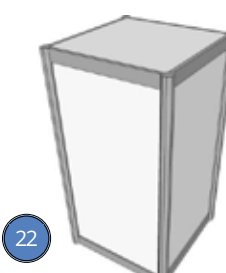

22
Information desk
H=1000
500x500



29
Showcase «Premium»
H=1000

XX — Number is mentioned in the table sheet of Form №2

Exhibition furniture



36

Coffee table
round shape



37

Coffee table
square shape



38

Two shelves Coffee
table with glass



41

Table "Hydra"



42

Oval shape
coffee table



43

Standard height glass
top round table

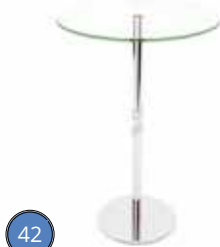

42

High bar table D700



43

Bar glasstable D800



37

Table H=750
600x600



38

Table H=750
1200x600



66

Coffee machine
(+1 kg Coffee)

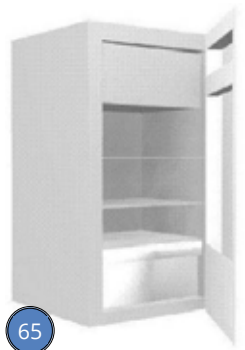

65

Refrigerator 80l



64

Refrigerator 150l

Visual images of additional equipment



Free-standing mirror



Tribune "Titan 2"



Tribune "Titan 1"



Гримерный столик с подсветкой



Free-standing Magazine holder "Sail"



Floor clothes rack



Rope fence (different rope's colors are available)



Fence post tape (red, black, blue)



Coat hanger on the floor



Metal shelving



LED spotlight on a pole 1 m



Круглый галогенный трековый светильник LIVAL CB-500 35-50 Вт — для точечной подсветки (теплый свет, крепятся на шинопровод, шинопровод кладется на балки)

Visual images of additional equipment



Chair "Vilmar"
black



Chair "Vilmar"
white



Chair "Boro"
black



Chair "Boro"
white



Bar stool "Latina"
black



Bar stool "Latina"
white



Bar stool "Marco"
black



Bar stool "Marco"
white



Two-seat sofa
(eco-leather/black)



Two-seat sofa
(eco-leather/white)



Three-seat sofa
(eco-leather/black)



Three-seat sofa
(eco-leather/white)



Chair standart
(Grey)



Chair
(eco-leather/black)



Armchair
(eco-leather/black)



Armchair
(eco-leather/white)

Visual images of additional equipment

Floristics



114

Aglaonema Friedman
30/11



114

Aglaonema Silver
40/120



115

Anturium
75/30



115

Aglaonema
70/30



116

Dracena
40/150



117

Pahira
40/190



118

Pahira Aquatica
27/140



119

Aglaonema Silver
17/55



120

Dracena Hawaiian
27/120



120

Dracena Compacta
27/100

TV-sets, digital and touch screens

TV-sets

The installation of a thin LED panel on the stand is the easiest and cheapest way to draw the visitor's attention. Thin plasma can be mounted on the stand, or directly on the wall. An interesting solution is the use of bright plastic overlays or painted wooden panels with cut-outs for screens.



42" Plasma screen with a floor stand

€318

50" Plasma screen with a floor stand

€373



LED modules

There is an endless possibility to create vivid video effects with LED screens: it could be a large video wall (or cube) in the center of the stand or cylindrical version of LED screen. Blocks of 500x500 mm are assembled into a screen of a given size and controlled by a laptop. The price includes: transportation, installation, a LED screen with a support (up to 1 meter), laptop, the work of a video engineer to set up and control during the exhibition.



You can order a LED screen of any size and configuration. The most popular option is a 3000x1500mm LED screen mounted on the back panel of the stand. Price is €2620.

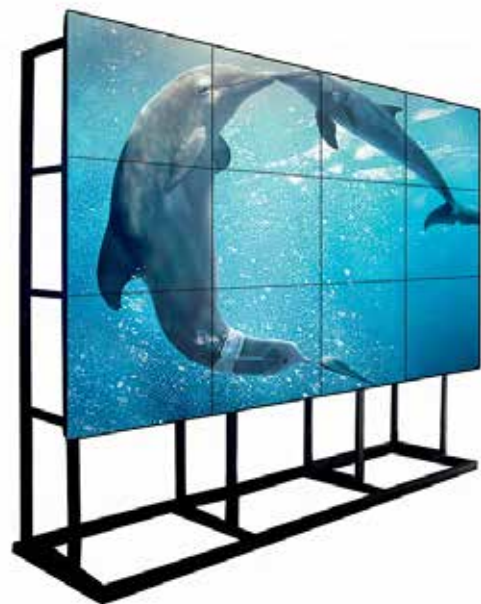

Ceiling hanging fittings

You are allowed to use not only the floor space, however the space above your stand is also available for you to use. Even a large and heavy pending fitting can be attached to the ceiling, creating a “second floor” of the stand floating in the air. The weight and dimensions of the ceiling pending fittings imply the required number of suspension points.



Useful Advice to save money: hang a large inflatable ball, flag or other bright object at one point.

Ceiling suspension point for pending fittings less than 10 kg: €239.

Ceiling suspension point for pending fittings less than 50 kg: €318.



Advertising advices

Make a focused strike: do not waste money on a “cold” audience, work selectively with future visitors to the exhibition, increase conversion and lower the cost of a contact. Choose one of the promotional packages and start to warm up the attention to your products.

Advertising packages include all media channels: social networks, website, personal mailings and advertising blocks in our magazines.



Advertising Campaign Plan:

- From January 2023 in the groups Moscow Dive Show, “Prededlnaya Glubina” Russia’s Dive Mag#1 (“Ultimate Depth”) and “Mir Podvodnoy Ohoty” (“The Spearfishing World”) on Facebook, Instagram and VK, as well as on the sites diveshow.ru, pglubina.ru and podvoh.ru, there will be bright publications about your company and its new products and suggestions.
- Email blast will be sent during month of February 2023 to registered visitors of the past and upcoming exhibition. It would be a perfect time to announce special promotions offered by your company for the exhibition.
- Each exhibition visitor will get of the “Prededlnaya Glubina”/Russia’s Dive Mag#1 (“Ultimate Depth”) and “Mir Podvodnoy Ohoty” (“The Spearfishing World”) February issue as a gift. That would be a great opportunity for your company to publish your advertising blocks and review articles. Advertising blocks are active for another two months after the end of the exhibition, in all major cities of Russia, Belarus and the Baltic States, until the next issues of the magazine are published.

Choose a convenient package (prices are from 8999 rubles) and start preparation

- In conformity with the chosen tariff type, you get: advertising blocks chosen size in the magazine. For Ad blocks 1/8 and 1/16 at your choice there are three sections: Classified tourism, Gear and Education. Blocks 1/3 and 1/1 placed individually on the right side of the page.

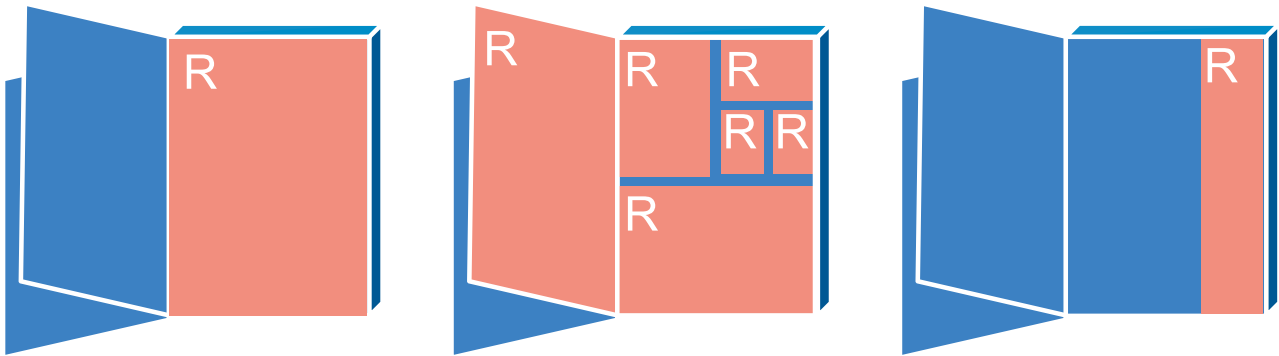

- Sample of news article in the magazine.



- News are in Moscow Dive Show groups, and in "Predelnaya Glubina" Russia's Dive Mag#1 ("Ultimate Depth") and "Mir Podvodnoy Ohoty" ("The Spearfishing World") magazines, in Instagram, Facebook или VK.



- Personalized special design invitation tickets.

- Ad Blocks are in thematic mailings to all visitors of the exhibition. 14,000+ verified addresses, a high percentage of openings and referrals, open analytics about the results of mailing ("Unisender" service).
- Radio announcements during the exhibition.

Тарифный план

Tariff Type	Size of Ad block	Information article I magazine	Quantity of posts in social medias	Quantity of groups in social medias	News on the site diveshow.ru	Block in mailings	Radio announcement at the exhibition	Personal invitations	Usual price / price for participant rub.
BASIC	1/16	-	1	1	-	-	-	10	14000/8999
STANDART	1/8	-	2	1	-	-	-	20	28000/15999
POWER	1/3	-	2	5	1	-	1	40	48000/29999
EXTRA	1/1	1/1	3	5	2	1	2	100	130000/89999
EXTRA	1/1	1/1	3	5	2	1	2	100	130000/89999

In addition to standard tariffs types, you can choose individual advertising tools.

Advertising info on the exhibition plan flyer

A double-sided A3 color flyer is given free of charge at the entrance to the exhibition. 20000 flyer copies will be published. This is the easiest way to inform visitors about promotion actions and sales, as well as help customers easily find your stand in the pavilion. Each advertising banner has an "arrow" sign indicating the location of your stand. Large banners price with premium location are 14,999 rubles. Standard size banner price is 8999 rubles.



Radio announcements

Loudspeakers in the exhibition halls will translate advertising Participants' announcements according to a strict schedule: not often than 3 ads per hour, in order do not bother visitors and company staff-on-stand by brakes the silence. Book in advance the required time slot. Announcement duration is 30 seconds.

- 1 announcement is €50.
- 3 announcements per/day €100.
- 10 announcements per/day €300.
- Saturday, 11th of February extra charge 50%.





Special projects

There are always wise solutions to realize ambitious plans, the scope of which is limited only by the existing budget, which the Exhibitor is ready to allocate. Few ideas as follows: an advertising or information article published in the magazine, equipment and gear tests, travel services reviews by magazine experts, underwater photography, meetings arrangement and B2B communication in conference rooms, branding of outdoor advertising and external media (invitations, bracelets, packages, etc.) as a separate exposition within the exhibition framework. Send your ideas and requests directly to the head of the Moscow Dive Show, Mr. Georgy Zdanovsky georgy@diveshow.ru

Personalized invitations

You can order a special series of personalized invitations edition for your guests. There is a quota of free invitations for exhibitors: 1 invitation per 1 sq. m. of the stand. We remind you that you can enter the exhibition only with a bracelet, or badge which is issued upon registration at the checkout area, but the transfer of a personal badge by the Participant does not solve the problem to let your guests in. We propose an excellent plan to print for you special edition of invitation tickets, which will have a separate field with your company name, stand's number, as well as an announcement of promotion actions and special offers to the bearer. Exhibition ticket price is €10; we'll give you 50% discount: minimal print of 20 tickets costs €100. (thus 250 rub. per one ticket). Maximum quantity of invitation tickets ordered by one participant is 100 copies.





Promoters and distribution of advertising materials

- The Exhibition participant must carry out the distribution of advertising materials focused to promote the Exhibitor in conformity with the following rules: any advertising actions carried out by the Exhibitor outside of his stand realized only with an Exhibition Organizer written agreement; any advertising activities carried out both within the Exhibitor's stand and outside the booth must not in any way violate the rights of other exhibitors and visitors of the Exhibition (as, for example, obstacle the passage, noise, smell, etc)
- The exhibitor organizes and manages the work and promotions of his Stand in a way do not disturb the flow of visitors in the aisles or violate the rights of other exhibitors and visitors. Body art concept must be confirmed in advance with the promoters. Topless options are prohibited.

Reminder:

- The rental price includes assembly, dismantling and adjustment of the rented equipment. All necessary connecting elements and cables provided free of charge.
- The rent of equipment as sound-amplifying, audio, video, overhead projectors for installation is possible only in specialized premises of the Gostiny Dvor complex and at the Exhibitors' stands.
- In case of own audiovisual devices (plasma panels) use, the Exhibitors must list them in Equipment delivery/removal Form.
- Installation of advertising vehicles, including mobile billboards outside of your stand is possible only on a paid basis and after the approval by the Exhibition Organizer.
- Banners or other visuals of the Exhibitor must be submitted for installation at least 10 (ten) working days before the installation day (order production day)
- Allowed Storage of Exhibitor's banners is only 3 days after dismantling and forbidden for a longer period.
- Distribution of advertising materials and/or other promotion actions aimed at advertising goods/works/services offered by an Exhibitor must be agreed by the Exhibition participant in conformity with the following rules:
 - advertising actions are carried out only after the Exhibitor pays the Organizer the price specified in Form No. 3, against the corresponding line tariff in Form No.3;
 - any advertising actions carried out by the Exhibitor outside the limits of his exhibition stand (regardless of whether they are paid according to Form No. 3 or not) can be implemented only if they are agreed in writing form with the Organizer;
 - any advertising activities carried out both within the Exhibitor's stand and outside must not in any way violate the rights as block the passage, noise, smell, etc. of other exhibitors and visitors of the Exhibition. The Exhibitor should organize and manage the work and promotions of his Stand in a way do not disturb the flow of visitors in the aisles or violate the rights of other exhibitors and visitors.

- During the entire period of the Exhibition, an Exhibitor is forbidden to advertise on the territory of the Exhibition (including within the booth of the Exhibitor) any exhibition events which are organized by third parties, i. e. not the Organizers, as well as goods/services/works offered by any persons not participating in the Exhibition.
- Violation of this provision will be considered by the Organizer as inappropriate and uncoordinated advertising, therefore the Organizer reserves the right to prevent distribution of such advertising by the Exhibitor in whatever manner it thinks fit up to denying access to the booth.
- To coordinate with the Organizer advertising activities outside its exhibition booth, the Exhibitor must no later than on December 10, 2022 submit to the Organizer a written application for an approval of an advertising event, indicating: the nature of the event, the territory on which it is planned to take place; the number of promoters (if any), and other moments which might be relevant in terms of free use of the territory of the Exhibition not occupied by booths. All information must be sent to sale@diveshow.ru.
- The necessity to coordinate the work of promoters, as well as all other advertising activities outside the booth with the Organizer is explained not by the Organizer's intention to limit advertising events of Exhibitors, but with the need to regulate and coordinate advertising events of all exhibitors so as to observe the rights and interests of each and every Exhibitor.



BADGES REQUEST MOSCOW DIVE SHOW 2023

Form №4

Name of the organization

Booth

	Last Name	First name	Patronymic
1
2
3
4
5
6
7
8
9
10
11
12
13
14
15
16
17
18

VIP-Parking

	Brand and model of the vehicle	Registration plate number
1
2
3



DELIVERY/REMOVAL FORM MOSCOW DIVE SHOW 2023

Form №5

To be filled in 3 copies

Name of the organization

Booth

Herewith we apply for the permission to move-in/ move-out the below listed exhibits and booth equipment to be demonstrated at MOSCOW DIVE SHOW 2023 held at Gostiny Dvor Complex from Feb 9 to 12, 2023.

Exhibit items list (with IDs of TV, video equipment and household appliances)

	Amount
1
2
3
4
5
6
7
8
9
10

First and last names of the Company's employees performing set-up and dismantling of the booth
(the pass will be valid for set-up/dismantling period only)

	Last Name	First name	Patronymic
1
2
3
4
5
6

Corporate seal

Company's CEO name	Signature	Date
.....

ENTRANCE ACCESS TO MOSCOW DIVE SHOW 2023

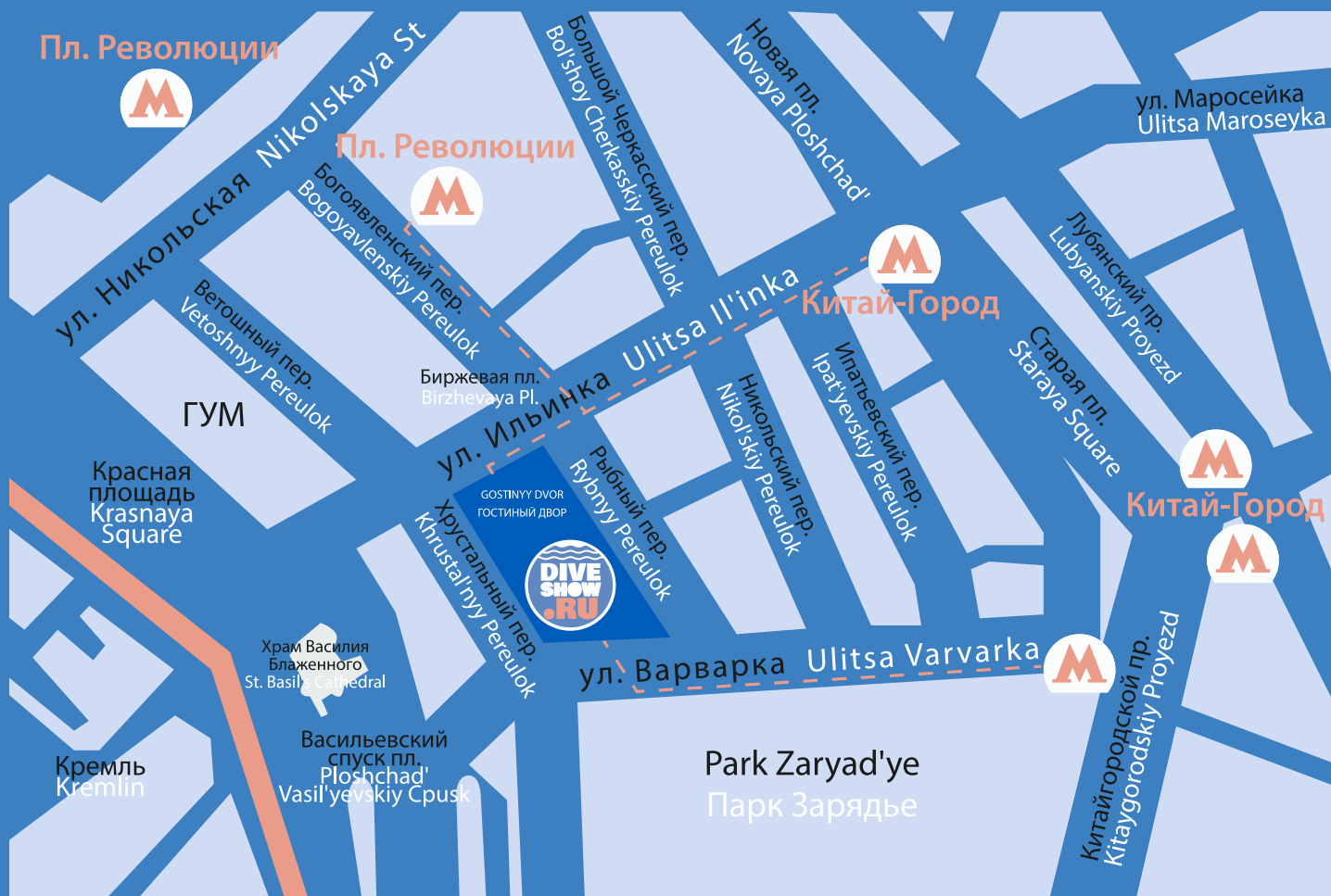

Заезд на выставку разрешен компаниям, полностью оплатившим участие!

Компании, имеющие какие-либо задолженности по оплате выставочной площади и/или заказанного дополнительного оборудования и услуг, НЕ БУДУТ допущены на выставку!

Порядок заезда:

Access to the Exhibition Moscow Dive Show 2023 (Trade Complex "Gostiny Dvor"):
Dear friends, there are two options to get the location of exhibition Moscow Dive Show:

Option № 1

Issue one-time entrance pass for cargo vehicle for the zone with limited transport circulation. You can get the detailed information and conditions to get this service on the official site MOS.RU!

The name of this service is: Get the pass for the cargo vehicle on the territory of Moscow city (MKAD, TTK, Garden ring). The pass is free of charge and only one-time use. Terms to get such official pass are 8 hours (not more). Better to issue one year pass if you need to make regular trips.

(Detailed instruction is here: <https://www.mos.ru/pgu/ru/services/procedure/0/0/7700000010000164773/>)

Option № 2

Transport cargo companies with a permanent pass for the center of Moscow (Authorization to drive in Garden Ring limits).

Authorized cargo forwarders: (PRICES ARE SUBJECT TO CHANGE!)

Service-Logistic (<https://www.sl-24.ru/gruzoperevozki-s-propuskom.htm>) Middle price for car under 1.5 tons (4 hours): 2660 rub.

Gruzovikhof (<https://msk.gruzovikhof.ru/ceny/do-1-5-tonn>) Middle price for car under 1.5 tons (4 hours): 2890 rub. Under 3tons (4 hours) — 4800 rub. + Garden Ring access: 1500 rub. = 6300 rub. Under 5tons (4 hours) — 6500 rub. + Garden Ring access: 1500 rub. = 7000 rub.

In case of any pass problem or other always contact us by email (sale@diveshow.ru) or by phone: +7 (926) 456-0-456

Access through cargo gates №16 in Varvarka street, or gates №18 in Ilyinka street only by appointment. One month before the Exhibition we issue the link for online order of unloading time slot

Work procedure at the exhibition

1. Access to the venue

Entrance to the exhibition strictly against the badges! Exhibitor badges allow exhibitors and their staff access to the pavilions during the exhibition from 9th up to 12th of February 2023.

2. Exhibitors' registration

Exhibitors' registration and badges (permanent pass) for staff who will work on your Stand, will take place in Exhibition Direction Office 7th and 8th of February 2023 from 09:00 to 20:00.

** To obtain passes, you must send in advance (before February 1, 2023) by e-mail info@diveshow.ru to the organizers Form No. 4 with the names of the employees.*

3. Security and working schedule on the stand

- Pay your attention that during mantling/dismantling/exhibition the Exhibition pavilion is closed. All pavilions are under guard and security control from 20:00/21:00 up to 10:00AM.
- Exhibition Participants have to be informed that the stand is under protection of guardians from 20:00 to 21:00. It is prohibited for anyone to stay in closed and sealed halls from 20:00/21:00 to 10:00.

We kindly ask you to ensure the presence at least of one representative at the stand during the exhibition from 10:00 to 20:00!

In order to avoid cases of loss of things during the exhibition (check-in, work days, check-out), we kindly ask you to keep eye on of your personal property and valuable equipment/belongings at the stand!

OWNER BEARS RESPONSIBILITY for personal property and valuable equipment during the exhibition!

4. Additional equipment and services

- In case of necessity to order any additional equipment that is not included in the list of Forms No.2 and No.3, please contact the Exhibition Organizer for information on the availability of such equipment and prices (sale@diveshow.ru).
- Applications for additional equipment or services are submitted by January 31th, 2023.
- The cost of applications/orders for additional equipment or services sent or modified by the Customer after February 1, 2023, will increase by 50% of the cost specified in the Exhibitor Manual.
- The cost of applications/orders for additional equipment or services received or modified by the Customer less than 7 (seven) days before the start of the event installation by 100%.
- Orders during installation and during the exhibition must be paid with a 100% extra charge.
- Reasonable claims for the timing, quality and scope of services provided by the Exhibition Organizer are accepted until the last day of the Exhibition installation. Otherwise, the service is considered to be provided on time, in full and with proper quality.

5. Advertising materials and promotions

- Distribution of advertising materials or other types of advertising activities outside their stands should be carried out by the Exhibitor only after agreement with the Exhibition Organizer and payment according to Form No.3.
- The exhibitor should organize and carry out the work of his exposition in such a way as not to impede the flow of visitors in the aisles and not create a threat or violation of the rights of other exhibitors and visitors.
- Placement of advertisements for third-party exhibition events, as well as advertisements and advertising materials of organizations, institutions, firms and companies that do not take direct part in the exhibition, within the entire exhibition space is strictly prohibited.
- In case of violation of described above rules, the Organizer reserves the right to apply sanctions to the Exhibitor up to the closure of the exhibition stand without paying any compensation and without refund that paid by the Exhibitor to the Organizer for participation in the exhibition.
- The Exhibitor must get an agreement for promotion events with the Organizer of the exhibition. This requirement is not intended to restrict your advertising campaigns, but is intended to regulate and coordinate advertising campaigns for all exhibitors. In case of using of own audiovisual devices (plasma panels, etc.), Exhibition Participants must list them in the letter of goods in/out.

Exhibits Dismounting/Removal letter:

1. Exhibits and exhibition equipment are at your stand until 18:00 on February 12, 2023. The dismantling of the exhibition constructions begins strictly from 18:30 on February 12th, 2023 and lasts until 23:55 on February 12th, 2023.
2. Before you start the removal of the equipment and exhibits, your representative must contact the Exhibition Directorate with the remaining copy of the exhibits delivery/removal letter. The representative of the Directorate stamps the letter with "REMOVAL IS PERMITTED". You should show this document stamped to the guard at the cargo gate while removing exhibits and equipment.
3. All Exhibitor property, equipment, structures and exhibits must be removed from the venue at 23:55 on February 12th, 2023.
4. The Exhibitor must return all the rented equipment before the removal of the exhibits. Otherwise, the Participant is not allowed to take out exhibits from the Exhibition pavilion.
5. Removal of exhibits on the last day of the exhibition is allowed by agreement with the Exhibition Organizer.



125362, Moscow, Vodnikov street. 2/bldg. 17, office 9
+7 (926) 456-0-456
www.diveshow.ru